

PROCESSING INSTRUCTIONS



# FLOW





# Processing instructions naturheld FLOW

Version Nr.: 001,

## ■ General information

The processing of naturheld FLOW wood fiber blow-in insulation is usually done by machine. The compressed wood fiber bales are loosened into loose fibers using a blowing machine. These fibers flow into the cavities of the various building components by means of an air stream via hoses, where they are compacted into a non-settling insulation mat. Naturheld wood fiber blow-in insulation may only be processed by trained and certified specialists.

Our naturheld FLOW wood fiber blown-in insulation can be used for industrial prefabrication, construction site installation and renovation work.

Building physics requirements such as heat, moisture, sound and fire protection must be taken into account in advance. At [www.ubakus.de/u-wert-rechner](http://www.ubakus.de/u-wert-rechner), building components can be calculated easily and reliably with naturheld products.

Blown-in insulation does not replace an air or windtight layer. These seals must be created with appropriate air or wind sealing membranes or board materials.

Blow-in cavities must be free of nails and screws as these can damage the blow-in hose and can also disrupt the blow-in process.

Installation elements or penetrations (e.g. solar pipes etc.) where temperatures  $>80^{\circ}$  are to be expected should not be installed in the naturheld wood fibre insulation materials without additional fire protection measures. For connections to chimneys, the relevant fire protection regulations must be observed and approval must be obtained from the responsible district chimney sweep.

When working with naturheld Flow wood fibre blow-in insulation, all persons involved must wear a fine dust mask with a dust filter (at least P2).

Material lying on the floor is not recommended to be blown in again, as dirt and foreign objects such as nails, stones etc. can cause damage to the blowing machine.

After completion of the work, the construction site must be swept clean.

## ■ Construction site preparation

Good site preparation is a basic prerequisite for smooth, safe and successful processing:

Precise scheduling ensures that everything runs smoothly. No other trades should work on the components at the same time. Clarify the space requirements and accessibility of the components to be insulated.



# Processing instructions naturheld FLOW

Version Nr.: 001, Valid from 04.07.2024

The limits of cavities must be known to the installer. Installation parts and changes must be marked. This prevents partial areas from not being insulated.

Detailed drawings, planning documents or detailed solutions and penetration seals must be available to the installer and interfaces must be clarified in advance::

- Who is responsible for creating and closing the injection openings?
- Who is responsible for completing the airtight or windtight layer?

Plaster base boards must not have been treated with the plaster system before blowing in.

Airtight cavities must be filled with venting nozzles or lances, or an additional venting opening must be provided.

When using vapour control layers, the maximum batten spacing of the substructure must not exceed 42 cm. Wood fibre insulation boards should be at least 35 mm thick.

The minimum thickness of the components to be blown in with naturheld Flow is 10 cm, the maximum thickness is 40 cm. The clear width of the areas to be blown in is ideally between 10 and 80 cm.

Walls or vertical components >350cm must be sealed off.

Narrow fields <10cm and small fields <0.25m<sup>2</sup> should be insulated in advance with naturheld FLEX for economic reasons.

The fields to be insulated must each be closed before the fibres can be blown in. Any gaps up to 10 mm wide are closed by the fibres themselves during blowing.

For pitched roofs, a positioning board must be provided at the ridge.

Power supply:

- The VDE guidelines must be observed.
- Fuse protection for the 230 & 400 volt blowing machines with at least 16 amps, Euro CEE plug, 5-pin with neutral conductor (C16 fused)
- The connection cables to the machine and the amplifier station have a cross-section of at least 2.5 mm<sup>2</sup>.
- Cable lengths of more than 30 metres must be avoided and cable drums must be fully unwound.
- The machine should be connected to its own power circuit. Too little power can lead to machine malfunctions and loss of performance.

The settings of the respective machine manufacturer must be used when blowing in. For each new application, it is recommended to check and document the machine settings and required blow-in density using a test box or a selected test field. Samples can also be taken with the injection cylinder for orientation purposes. (page 9)

After completion of the blowing-in work, a site report must be drawn up (page 14).

## Storage and transport

The material must be inspected on delivery, instruction leaflets must be observed and the pallet sticker must be kept together with the delivery notes.

naturheld FLOW must be stored in a dry place and protected from UV light.



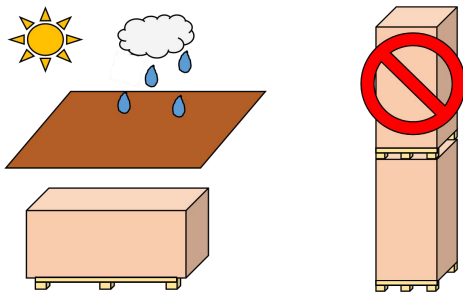

The packaging should only be removed during processing.

The pallets must not be stacked on top of each other.



## Areas of application

Areas of application according to DIN 4108-10:2015

<b>DZ</b>	Insulation between rafters, doubled layer roofs, not walkable but accessible top floor ceilings	
<b>DI-zk</b>	Interior insulation of the ceiling or roof underside	
<b>WH</b>	Compartment insulation of walls in timber frame and timber stud construction	
<b>WI-zk</b>	Interior insulation of walls	
<b>WTR</b>	Interior insulation of room partitionwalls	

Tensile strength: zk = keine



# Processing instructions naturheld FLOW





Version Nr.: 001, Valid from 04.07.2024

## ■ Properties naturheld FLOW

Areas of application

- Insulation between rafters
- Compartment insulation of walls in timber frame and timber stud construction
- Insulation of wooden joist ceilings
- Insulation of the attic ceilings
- Insulation of installation levels
- Insulation of ribbing on mineral substrates

### TECHNICAL DATA:

Approval		ETA-23/0125	
DoP / Declaration of Performance		Flow_01.09.24	
Density		kg/m <sup>3</sup>	33-45
Nominal thermal conductivity $\lambda_D$ EU		 W/(mK)	0,038
Rated thermal conductivity	$\lambda_B$ DE	 W/(mK)	0,040
	$\lambda_B$ CH	 W/(mK)	0,038
	$\lambda_B$ AT	 W/(mK)	0,039
Fire behaviour according to DIN EN 13501-1		E	
PN-EN 13823+A1: 2022-12		B-s2,d0	
Building material class according to DIN 4102-1		B2	
Full declaration		Wood fibres, ammonium sulphate (fire retardant)	
Water vapour diffusion resistance factor		$\mu$ 1-2	
Specific heat capacity		J/(kgK)	2100
Waste key numbers according to AVV		030105/170201, Wood and wood-based materials, waste wood category A II	

## ■ Packing/ formats

Packaging of the bales	Weight per bale (kg)	Bales per pallet	Weight of the pallet (kg)
foiled	15	21	315
unfoiled	20	18	360

### SINGLE-VARIETY LOADING (ON STANDARD TRUCK LOADING SPACE 2,40 X 13,60M)

Pallet dimensions (approx.)	Pallets per truck
1200 x 800 x 2550 (L x W x H)	33

## ■ Minimum requirements for machine technology

In principle, the following applies:

Air pressure at least 360 mbar.

Air flow rate over 600 m<sup>3</sup>/h

Depending on the injection technique (lance, needle, hose), the minimum requirements may not be met.

However, this must be checked on site under the customer's own responsibility and in compliance with the minimum densities.

The requirements for the machine technology must be clarified with the respective machine manufacturer and the settings of the respective machine manufacturer must be used when blowing in.

## ■ Position of injection openings

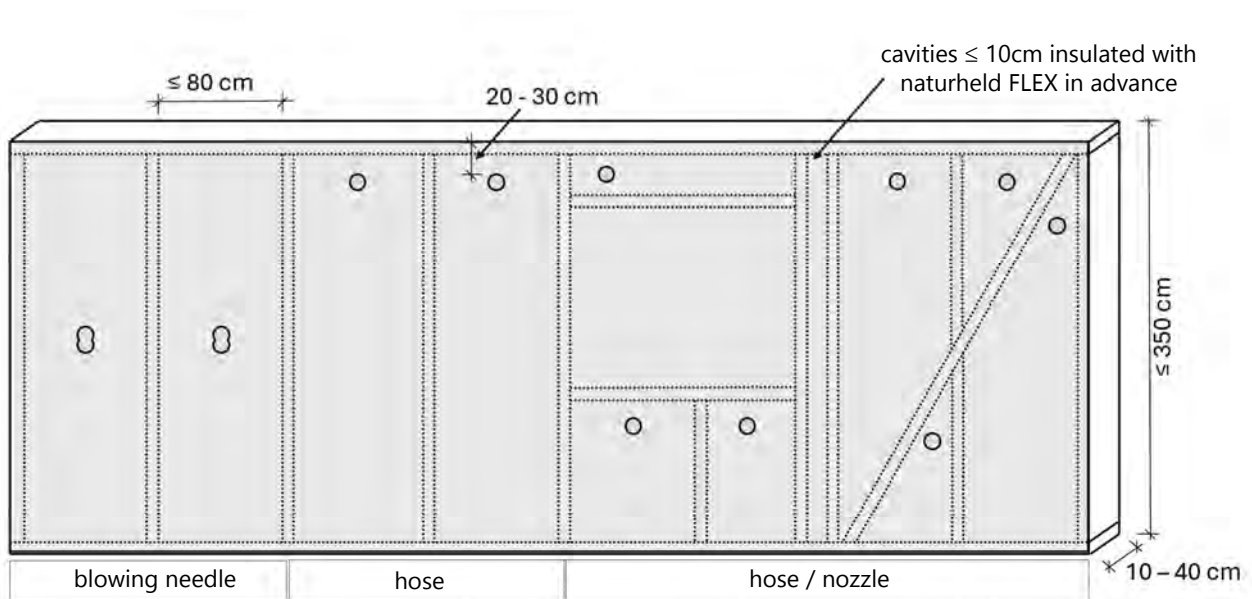

Defined holes of 105 or 120 mm are only required when using sealing plugs.

The holes should generally be adapted to the element depth. This means that the smaller the element depth, the larger the hole should be to enable effective and easy work.

- Creating and closing injection openings

Hole saw with ejection system for all hard board materials:

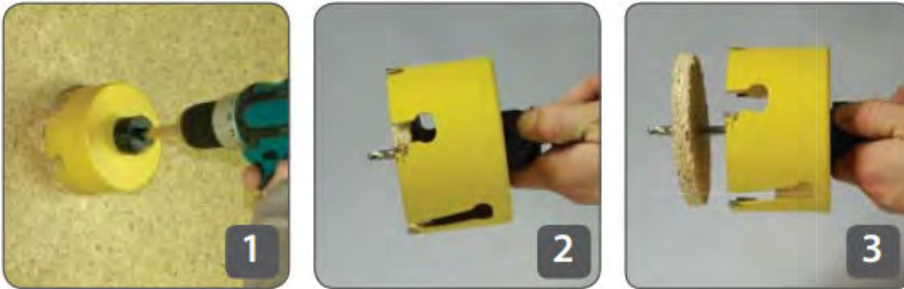

Source: X-floc

<https://lochsagen.com/products/lochsagen/multi-purpose/>

Blow-in holes can be closed with wide pieces of adhesive tape or pre-punched sealing plasters:



Hole saw HF for soft wood fibre boards:

## processing

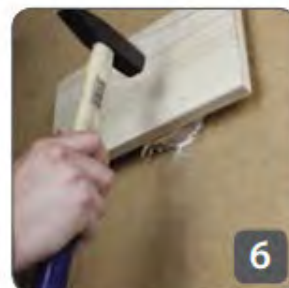
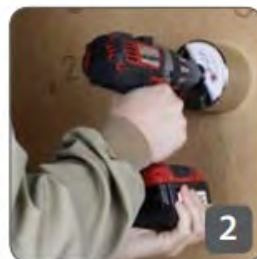

Source: X-floc

## ■ Use of membranes

Only use sealing membranes that are approved by the manufacturer for blow-in insulation.



The distance between the staples used to fix the vapour barrier to the substructure is max. 10 cm.

Alternatively, the use of hard fibre strips or an additional batten along the rafter is recommended.

If the membrane is laid crosswise, it is recommended that the overlap bonding in the centre of the field is additionally reinforced crosswise with short pieces of adhesive tape. Alternatively, an additional batten can be installed along the adhesive joint for mechanical protection.

The batten spacing of the substructure should not exceed a maximum of 42 cm.

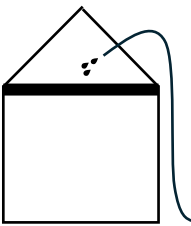
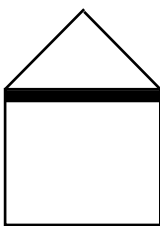
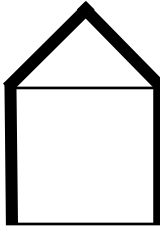
## ■ Blow-in densities

Compression table naturheld FLOW [kg/m <sup>3</sup> ]			
Open roof	Ceilings/ floors	Roof/ walls	Prefabricated components
			
<b>33</b>	<b>35</b>	<b>38</b>	<b>42</b>

Maximum size of the blow-in fields in walls:

Height ≤ 350 cm Width ≤ 80 cm Minimum thickness ≥ 10 cm Maximum thickness ≤ 40 cm

For larger blow-in fields or deviations, processing must be individually coordinated with naturheld GmbH's application technology department.

In addition to the blown-in minimum density (table above), a uniform distribution of the fibres in the cavity is also a prerequisite for settlement resistance.

naturheld FLOW wood fibres cannot be over-densified. A higher bulk density than stated in the table does not affect the technical properties, but increases the safety against settlement and physical influences when installed.

For compacted blowing > 24 cm, blowing with a blowing needle or blowing lance is recommended.



## ■ Checking the blow-in density

Checking and testing the blown-in compartments on the construction site is a prerequisite for fulfilling the quality requirements.

Inspection of machine technology:

The blower performance must be checked before each use. (see machine manufacturer's operating instructions)

Checking the raw density in the fields on the construction site:

- Calculate volume over 2 -3 fields
- Compare with the quantity blown in
- Repeat the process for each floor, as the difference in height can affect the pressure conditions

According to the approval, a calculated determination is necessary. See construction site protocol p. 14

For additional orientation, the installation density can also be checked with a density test set (piercing tube).

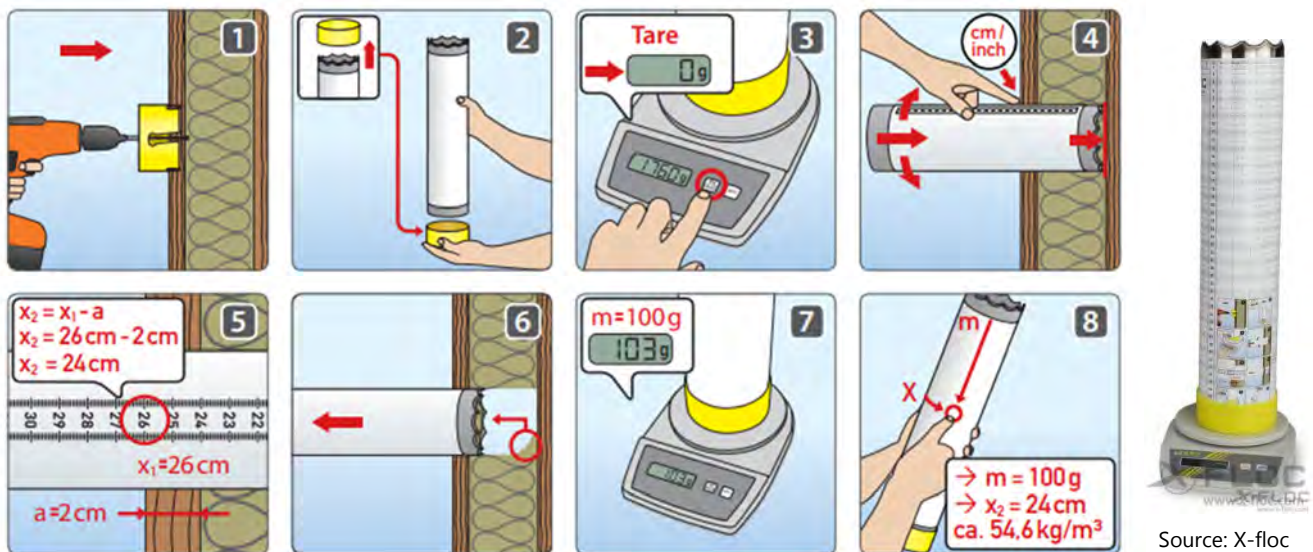

## ■ Blowing-in process: Dense packing

In dense packed blowing, the wood fibre is inserted into completely sealed cavities through a blowing opening. Initially, the cavity is generally filled with loose wood fibre from bottom to top. As the filling level increases, the insulation material is compacted by the increasing overpressure and at the end of the blowing process, the space around the blowing opening fills up.

### Blowing in with hose



Source: X-floc

Filling with an injection hose is probably the best-known method. A distinction is made between transport and delivery hoses and the injection hose.

The transport hose is made of flexible PU / PVC and is smooth on the inside. It is basically used to transport the material from the injection machine to the injection hose. The stiffer blow-in hose is made of low-wear and durable PE and is rough/corrugated on the inside. Its rigidity makes it easier to guide in the compartments and the corrugated inside also loosens up the fibres and distributes them better in the compartment.

### Blowing in with blowing needle

Procedure using the example of a wall:

- 1 Insert needle
- 2 Swivelling
- 3 Pull out and turn upwards
- 4 Fill the upper area by swivelling

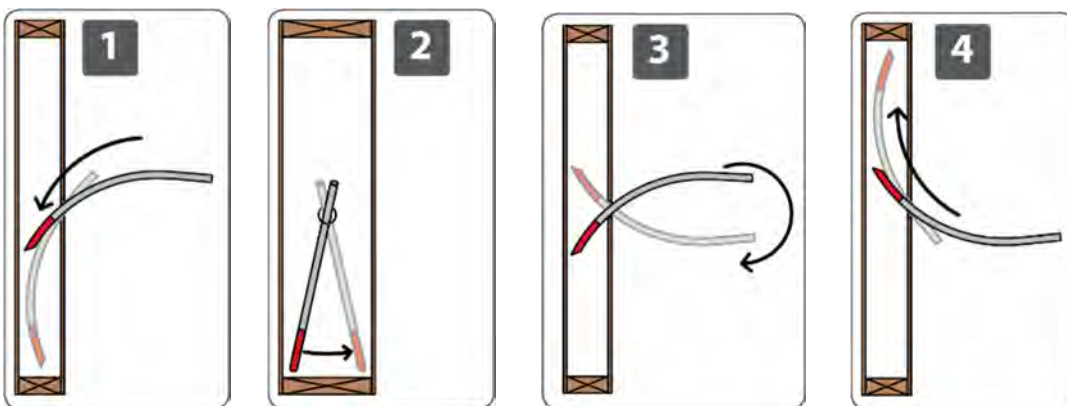

Source: X-floc

Example roof (5), ceiling (6):

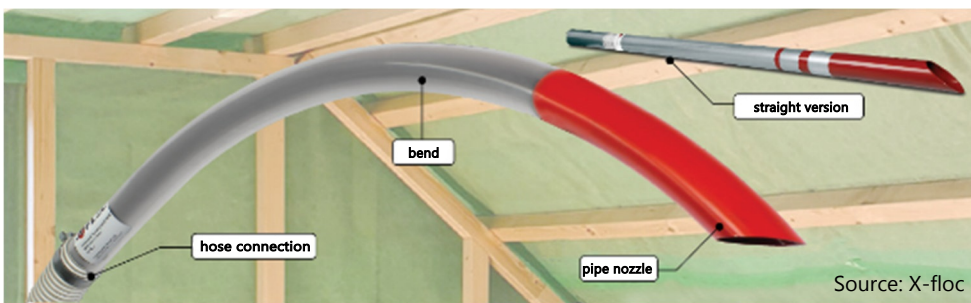
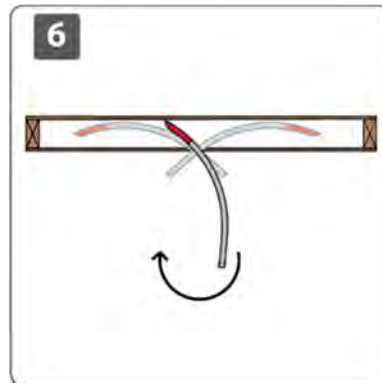

In principle, higher raw densities can be blown in with the blow-in needle.

It is very suitable for ensuring filling in the upper area of high insulation thicknesses in roofs and ceilings. It can also be used for post-compaction in fields that have already been blown in.

## Blowing in with lances and telescopic blowing lances

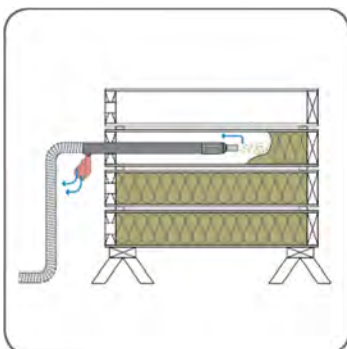

The blow-in openings are created into the frame. The rigid pipe allows a higher raw density to be introduced and also compacted. In addition, the distribution in the cavity is very even.

## Sealing aids

When blowing in with a hose, blowing needle or blowing lance, a sealing sponge or blowing aid is recommended.



## Blowing in with venting rotary nozzle

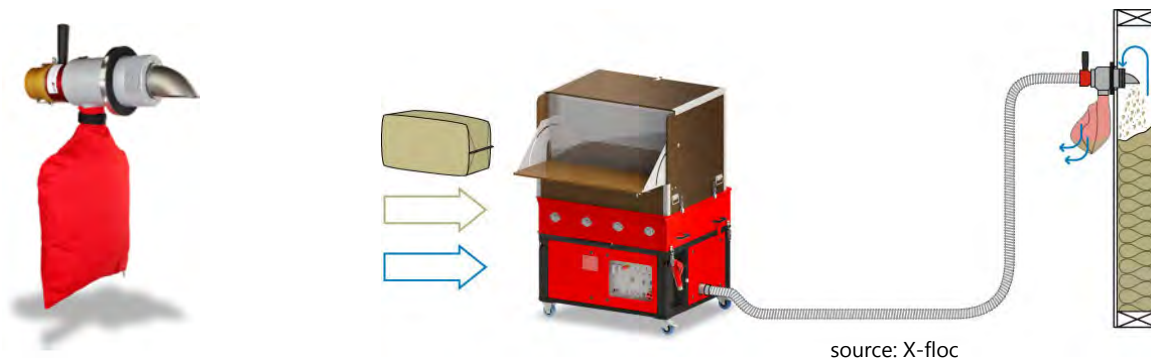

In the case of small or air-impermeable constructions (e.g. under windows and jambs, interior walls, etc.), it is recommended to use a venting rotary nozzle.

**Attention!** For large air-permeable fields, the maximum filling height must not exceed **1.50 metres**.

## Partially and fully automated blow-in plate

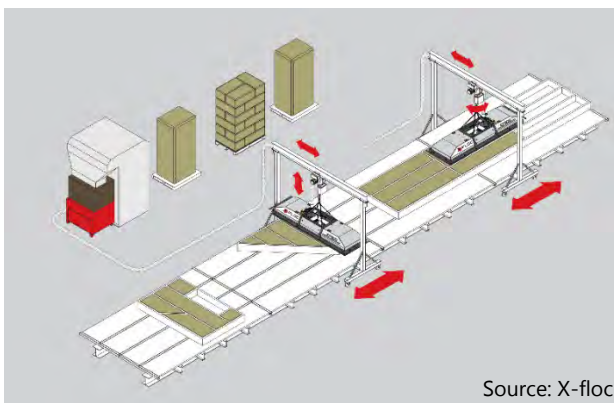

With partially and fully automated stationary filling technology, wall, ceiling and roof elements planked on one side are filled on transport tables with a blow-in panel from the upper, still open side.

The blow-in panel seals through its own weight and appropriate devices during the blowing-in process, and the elements are only sealed with a second panelling after the filling process.

## Open inflating

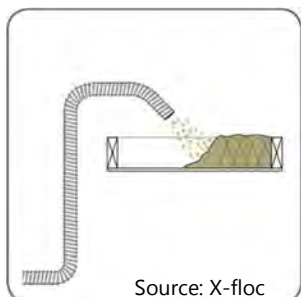

With open inflation, the thermal insulation material is applied to a surface that is open at the top. The top storey ceiling or vaulted ceilings are often insulated in this way. In the simplest case, it can be applied using a hose or a rigid pipe.

The area to be inflated must be cleaned before starting work and openings between the masonry and the rafters must be sealed with adhesive tapes, boards or film strips.

When connecting to chimneys, the relevant fire protection regulations must be observed and approval must be obtained from the responsible district chimney sweep.

Floor stairs must be sealed to insulation thickness if necessary.

Recessed luminaires/spots must be covered with a fire protection enclosure in accordance with the manufacturer's specifications and electrical junction boxes should not be insulated.

To reduce dust formation, the air flow rate should be reduced and the end of the hose should be kept in the insulating material if possible. Alternatively, the fibres can be moistened, which leads to a slight cross-linking and a more stable surface of the fibres.

Information:

When calculating the thermal resistance of exposed insulated components with naturheld FLOW wood fibre blown-in insulation, the following applies: **Nominal thickness = installation thickness – 9%.**

Calculation table according to ETA-23/0125:

Calculated material thermal resistance according to ETA-23/0125					Density 33 kg/m <sup>3</sup>		Insulation thickness after settlement [cm]
Installed insulation thickness [cm]	Thermal conductivity [W/m <sup>2</sup> *K]				Insulation material weight [kg/m <sup>2</sup> ]	Number of 15 kg bags per 10m <sup>2</sup>	
	EU 0,038		D 0,040				
	U-value [W/(m <sup>2</sup> *K)]	R-value [(m <sup>2</sup> *K)/W]	U-value [W/(m <sup>2</sup> *K)]	R-value [(m <sup>2</sup> *K)/W]			
12	0,35	2,85	0,36	2,75	3,96	2,6	10,8
16	0,26	3,85	0,27	3,65	5,28	3,5	14,4
20	0,21	4,80	0,22	4,55	6,60	4,4	18,0
24	0,17	5,75	0,18	5,50	7,92	5,3	21,6
28	0,15	6,75	0,16	6,40	9,24	6,2	25,2
32	0,13	7,70	0,14	7,30	10,56	7,0	28,8
36	0,12	8,65	0,12	8,25	11,88	7,9	32,4
40	0,10	9,65	0,11	9,15	13,20	8,8	36,0
44	0,09	10,60	0,10	10,05	14,52	9,7	39,6
48	0,09	11,55	0,09	11,00	15,84	10,6	43,2
52	0,08	12,55	0,08	11,90	17,16	11,4	46,8
56	0,07	13,50	0,08	12,80	18,48	12,3	50,4
60	0,07	14,45	0,07	13,75	19,80	13,2	54,0



# Construction site protocol

## naturheld FLOW - Wood fibre blow-in insulation

Thermal insulation material made from loose, unbound wood fibres

**naturheld FLOW**  
**Wood fibre blow-in insulation**

DIN EN 13501-1 , Class E  
 $\lambda_B$  0,040 W(mK) according to MVVVB  
 $\lambda_D$  0,038 W(mK) according to ETA-23/0125

**Production date:**  
**(Pallet inserter)**

\_\_\_\_\_

\_\_\_\_\_

\_\_\_\_\_

<p><b>Executing company</b>  <b>naturheld specialised company</b></p> <p>Company: _____          Street/house no.: _____          Postcode/City: _____          Telephone: _____          E-Mail: _____</p>	<p><b>Building project</b></p> <p>Name: _____          Object: _____          Street/house no: _____          Postcode/City: _____          Telephone: _____          E-Mail: _____</p>
---	---

**Compaction values in the components:**

Construction component Roof, ceiling, wall, open inflation, etc.	Thick- ness [cm]	Insulating surface less wood content [m <sup>2</sup> ]	Processed quantity [kg]	Raw density calculated [kg/m <sup>3</sup> ]	Raw density measured [kg/m <sup>3</sup> ]	Blow-in process

**This is to confirm that the above-mentioned construction site has been carried out in accordance with the European Technical Assessment (ETA-23/0125) and the processing instructions for naturheld FLOW wood fibre blow-in insulation.**

\_\_\_\_\_  
Place, date

\_\_\_\_\_  
Signature/stamp naturheld specialised company

\_\_\_\_\_  
Place, date

\_\_\_\_\_  
Signature of the customer



**naturheld GmbH & Co. KG**

Parksteiner Weg 20  
92655 Grafenwöhr-Hütten

Telefon: +49 (0)9636 / 9209 - 5300

Fax: +49 (0)9636 / 9209 - 1899

E-Mail: [info@naturheld.global](mailto:info@naturheld.global)

**TECHNIK-HOTLINE**

Telefon: 09636 / 9209 - 5454

E-Mail: [technik@naturheld.global](mailto:technik@naturheld.global)

**[www.naturheld.global](http://www.naturheld.global)**